

SPT HAMMER

Hydraulically Operated Automatic Hammer

STANDARD EQUIPMENT

- MULTIPLE UNITS KEPT IN STOCK
- AUSTRALIAN DESIGNED AND MADE TO AS 1289.6.3.1
- DANFOSS HYDRAULICS
- VARIOUS THREAD ANVILS AVAILABLE AND IN STOCK
- RELIEF PROTECTED TO ALLOW USE ON ANY RIG
- 3RD PARTY RISK ASSESSMENT
- OPERATORS MANUAL

STANDARD SPECIFICATIONS

WEIGHT	190kg
MOTOR	100cc Hydraulic
CHAIN	Single row 5/8" pitch
WORKING PRESSURE	45 Bar
MAX PRESSURE	210 Bar
WORKING FLOW RATE	20 Litres/Minute
NOMINAL WORKING SPEED	25 Blows per Minute



**AUSTRALIAN
DESIGNED
& BUILT**

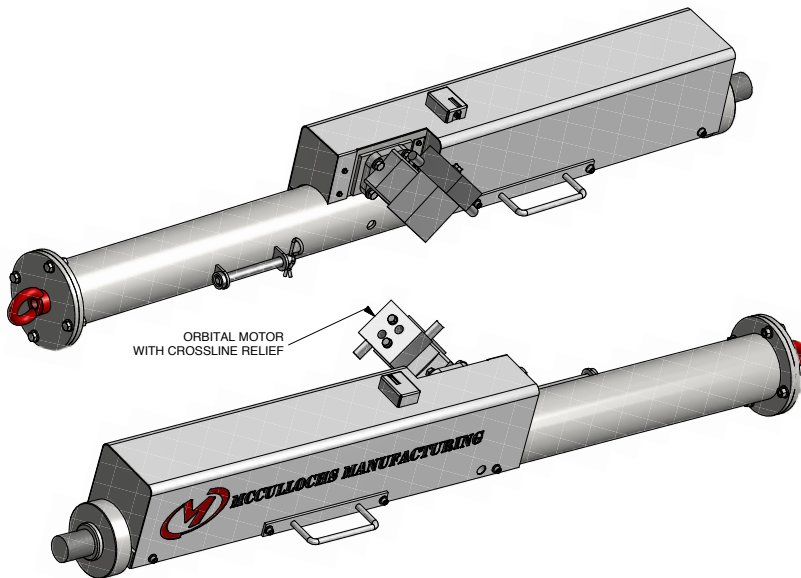

ORBITAL MOTOR
WITH CROSSLINE RELIEF

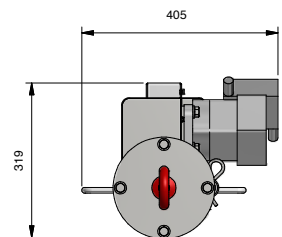
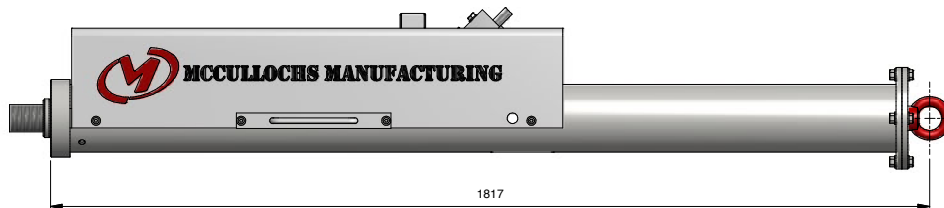

**DISCOVER OUR
CAPABILITIES**

Call: +61 3 5445 6900
Email: sales@mccullochs.com.au
Visit: mccullochsdrilling.com

