

# D&B 7-CR

Rod or compressor / pump carrier.



## STANDARD SPECIFICATIONS

WIRELESS REMOTE CONTROL FOR TRAMMING

54 HP ENGINE

5,500KG PAYLOAD

ENGINE CONFIGURATION - NTH/STH OR EST/WST

DRY WEIGHT (BASE MODEL) 4,500KG

## OPTIONAL EXTRAS

WALKWAYS AND HANDRAILS

RUBBER TRACKS PADS

WIRELESS REMOTE FOR TRAVEL

DECK OR CHASSIS ONLY CONFIGURATION

SELF-LOADING JACK LEGS

TRACK  
MOUNTED

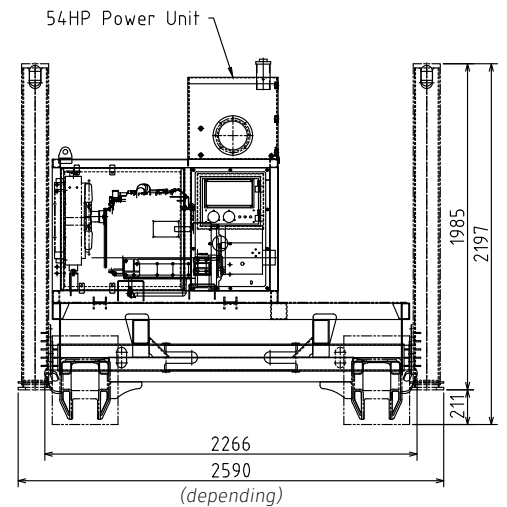
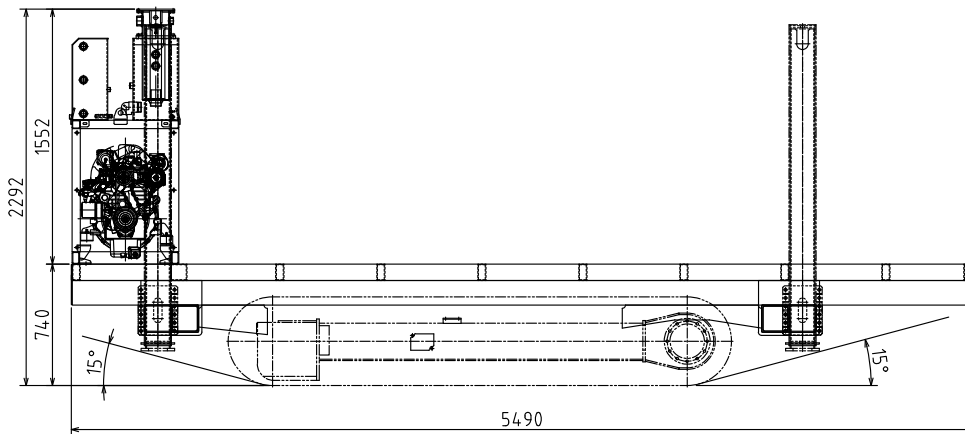
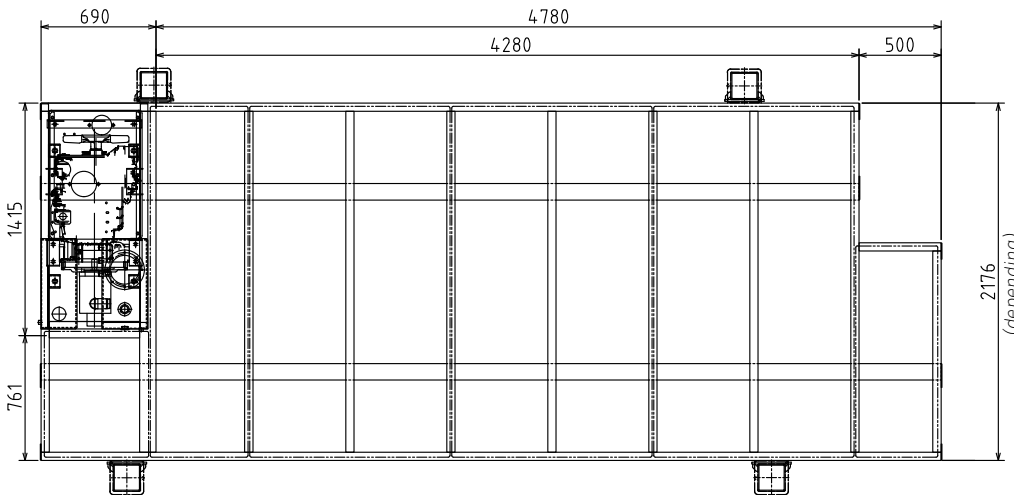

**DISCOVER OUR CAPABILITIES**

Call: +61 3 5445 6900  
Email: [sales@mccullochs.com.au](mailto:sales@mccullochs.com.au)  
Visit: [mccullochsdrilling.com](http://mccullochsdrilling.com)



**McCULLOCHS**  
DRILLING & BORING