

# D&B 15-CR

Heavy support carrier



**TRACK MOUNTED**

## STANDARD SPECIFICATIONS

WIRELESS REMOTE CONTROL FOR TRAMMING

ENGINE 105HP

15,000KG PAYLOAD

DRY WEIGHT (BASE MODEL) 11,000KG

## OPTIONAL EXTRAS

SELF-LOADING JACK LEGS

1000L SUB FUEL TANK WITH DIESEL PUMP,  
HOSE REEL AND DELIVERY NOZZLE

FOLDING WALKWAYS AND HANDRAILS

HANDLER OPERATOR CAB

ROD LOADER WITH WIRELESS CONTROL

1T, 2T OR 3T CRANE - WIRELESS CONTROL

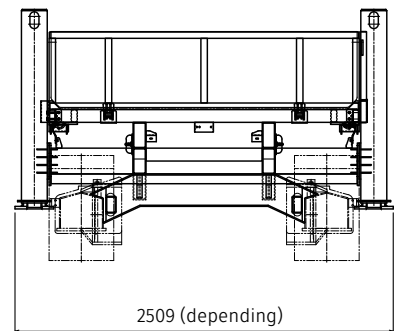
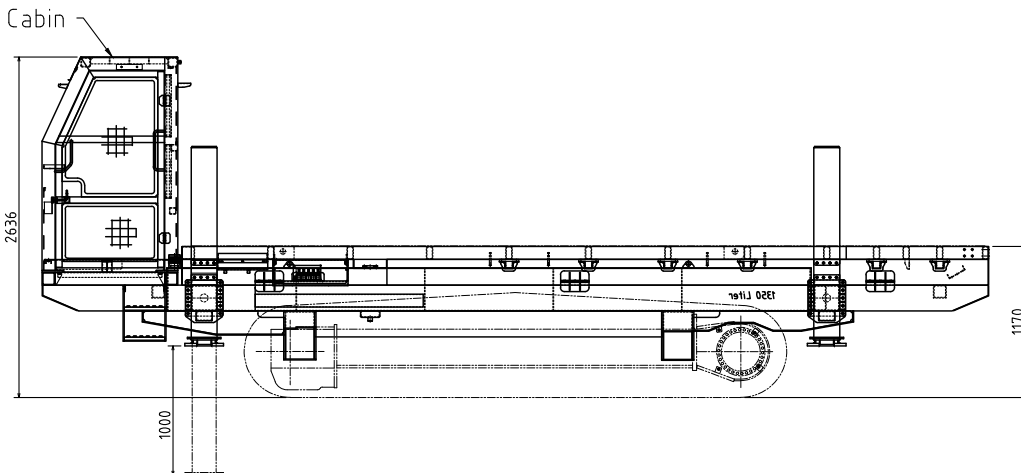
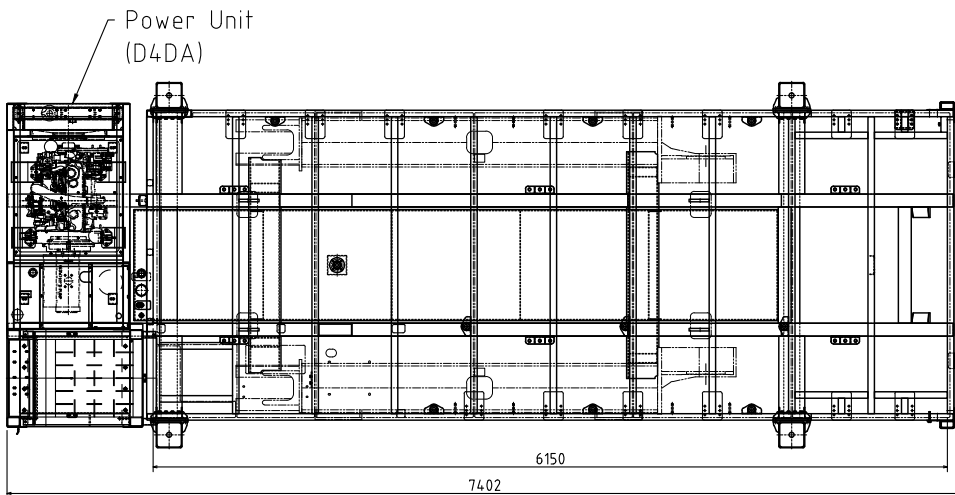

**DISCOVER OUR CAPABILITIES**

Call: +61 3 5445 6900  
Email: [sales@mccullochs.com.au](mailto:sales@mccullochs.com.au)  
Visit: [mccullochsdrilling.com](http://mccullochsdrilling.com)



**McCULLOCHS**  
DRILLING & BORING